

**WIRE CUT EDM  
EXPERTS**



# EC

## 步进型线切割机



## WIRE CUT EDM STEP MOTOR DRIVE

### HIGHLIGHTS

- Economic model C type Wire Cut EDM Machine
- PMI linear guide, C2 grade ball screw
- Cutting parameter automatic generate function
- Wire threading by motor function

Model	EC450	EC550	EC630
Worktable size	800 × 550	880 × 570	1000 × 750
Worktable travel	450 × 350	550 × 450	630 × 500
Max cutting height	300	300	300
Optional	500	500	500
Max cutting taper	6° /80mm	6° /80mm	6° /80mm
Optional	± 15 degree	± 15 degree	± 15 degree
Max Loading	300	400	600
Max cutting speed	300	300	300
Cutting accuracy	± 0.005	± 0.005	± 0.005
Best cutting roughness	0.9um	0.9um	0.9um
Water tank volume	120L	120L	120L
Machine power	2.5KW	2.5KW	2.5KW
Machine weight	1800	2100	2700
Machine size	1800 × 1700 × 2100	1900 × 1800 × 2100	2100 × 2000 × 2200

# SC

## 伺服驱动线切割机



## WIRE CUT EDM SERVO MOTOR DRIVE

### HIGHLIGHTS

- Servo motor drive, Pitch compensation function
- High Cutting Accuracy, reach to  $\pm 0.005\text{mm}$
- High Cutting Speed, reach 200 square  $\text{mm}^2$  per mint
- High Cutting Finishing, surface roughness reach  $0.8\mu\text{m}$

Model	SC450	SC550	SC630
Worktable size	800 × 550	880 × 570	1000 × 750
Worktable travel	450 × 350	550 × 450	630 × 500
Max cutting height	300	300	300
Optional	500	500	500
Max cutting taper	$\pm 6^\circ$ /80mm	$\pm 6^\circ$ /80mm	$\pm 6^\circ$ /80mm
Optional	$\pm 15^\circ$ /80mm	$\pm 15^\circ$ /80mm	$\pm 15^\circ$ /80mm
Max Loading	300	400	600
Max cutting speed	250	250	250
Cutting accuracy	$\pm 0.005$	$\pm 0.005$	$\pm 0.005$
Best cutting roughness	0.9 $\mu\text{m}$	0.9 $\mu\text{m}$	0.9 $\mu\text{m}$
Water tank volume	120L	120L	120L
Machine power	2.5KW	2.5KW	2.5KW
Machine weight	2000	2300	2700
Machine size	1800 × 1800 × 1900	1900 × 1900 × 1900	2000 × 2000 × 2000

# SCT

## 伺服驱动线切割机



### HIGHLIGHTS

- T machine body design
- Separate machine body design
- Higher cutting thickness, heavy loading machine body design

Model	SCT800	SCT1000
Worktable size	1350 × 850	1500 × 980
Worktable travel	800 × 630	1000 × 800
Max cutting height	300	400
Optional	500	500
Max cutting taper	± 6° /80mm	± 6° /80mm
Optional	± 15° /80mm	± 15° /80mm
Max Loading	800	1200
Max cutting speed	250	250
Cutting accuracy	± 0.005	± 0.005
Best cutting roughness	1.0um	1.0um
Water tank volume	120L	120L
Machine power	4KW	4KW
Machine weight	4000	5500
Machine size	2400 × 2600 × 2500	2500 × 2100 × 2000

定制生产分体式大行程机床

SCT1200、SCT1600、SCT2000

Customized production of split type large-stroke machine tools  
SCT1200, SCT1600, SCT2000

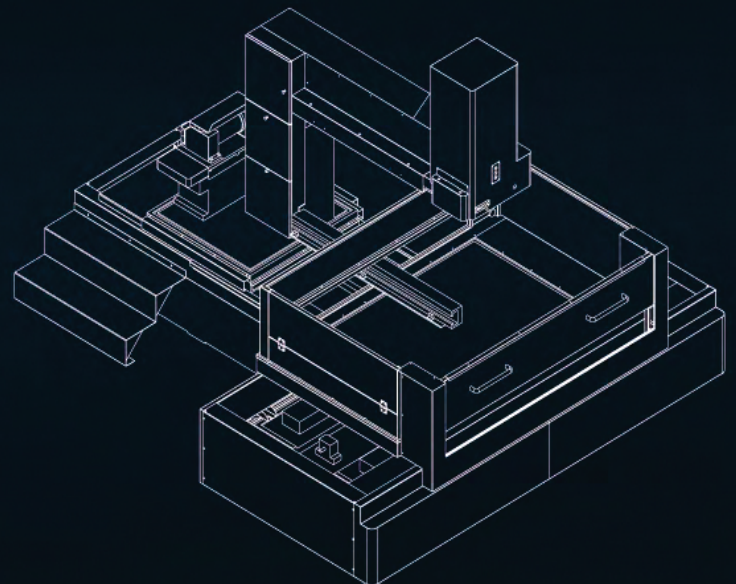

# DK77

普及型数控线切割机



# DK77

## F-TYPE WIRE CUT EDM

### HIGHLIGHTS

- The most popular model CNC wire cut EDM machine.
- AutoCut system base on Windows.
- Max reach  $\pm 45$  degree cutting.
- High pressure water tank.
- Multi cutting function to get better finishing.
- Super big size machine special to make.

Model	DK7725	DK7735	DK7745	DK7750
Worktable size	630 × 430	780 × 540	880 × 580	1000 × 650
Worktable travel	320 × 250	450 × 350	550 × 450	630 × 500
Max cutting height	300	500	500	700
Optional	/	/	/	1000mm
Max cutting taper	6° /80mm	6° /80mm	6° /80mm	6° /80mm
Optional	/	/	$\pm 30^\circ$ /80mm	$\pm 30^\circ$
Optional	/	/	/	$\pm 45^\circ$
Max Loading	200	400	400	600
Max cutting speed	250	250	250	250
Cutting accuracy	$\pm 0.005$	$\pm 0.005$	$\pm 0.005$	0.015
Best cutting roughness	1.0um	1.0um	1.0um	1.0um
Water tank volume	100L	100L	100L	100L
Machine weight	1200	1700	1900	2400
Machine size	1400 × 1010 × 1700	1900 × 1400 × 1900	2000 × 1600 × 1900	2200 × 1600 × 2100

Model	DK7763	DK7780	DK77100	DK77120
Worktable size	1150 × 750	1350 × 980	1640 × 1170	1380 × 1800
Worktable travel	800 × 630	1000 × 800	1000 × 1200	1200 × 1400
Max cutting height	700	800	700	700
Optional	1000mm	1000mm	Optional:1000mm	Optional:1000mm
Max cutting taper	6° /80mm	6° /80mm	6° /80mm	6° /80mm
Optional	$\pm 30^\circ$	$\pm 30^\circ$	$\pm 30^\circ$	$\pm 30^\circ$
Optional	$\pm 45^\circ$	$\pm 45^\circ$	$\pm 45^\circ$	$\pm 45^\circ$
Max Loading	800	1000	2000	2000
Max cutting speed	250	250	200	200
Cutting accuracy	0.015	0.02	0.02	0.02
Best cutting roughness	1.2um	1.2um	1.2um	1.2um
Water tank volume	100L	100L	100L	100L
Machine weight	3000	4500	6000	7000
Machine size	2300 × 1900 × 2100	2800 × 2100 × 2400	3100 × 2300 × 2400	3300 × 2350 × 2400

# MACHINING SAMPLES

## 加工案例



最佳表面粗糙度  $Ra \leq 0.8$   
The optimum surface roughness  $Ra \leq 0.8$



传统三刀平均效率  $45 \text{ mm}^3/\text{min}$   
西莫最高效率  $100 \text{ mm}^3/\text{min}$   
SIMOS CNC Max cutting speed reach  
 $200 \text{ mm}^3/\text{min}$



新型智能高频节能80%  
New smart high-frequency power supply  
80% saving

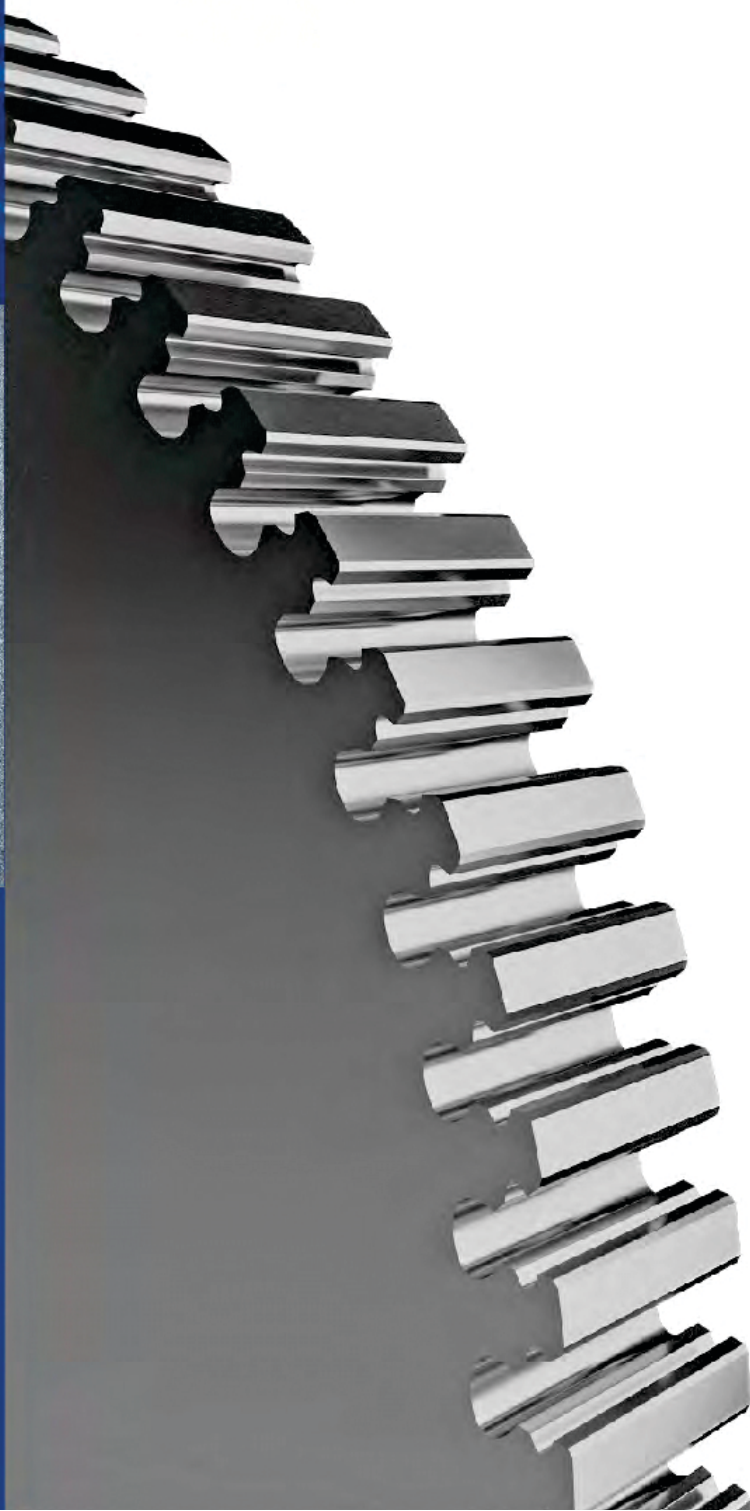

锥度切割 Taper Cutting

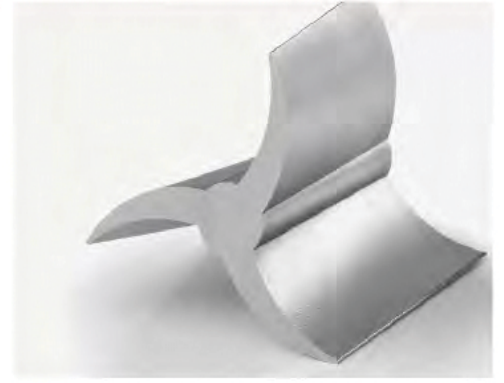
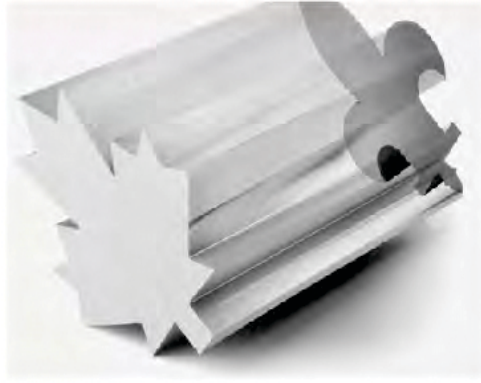
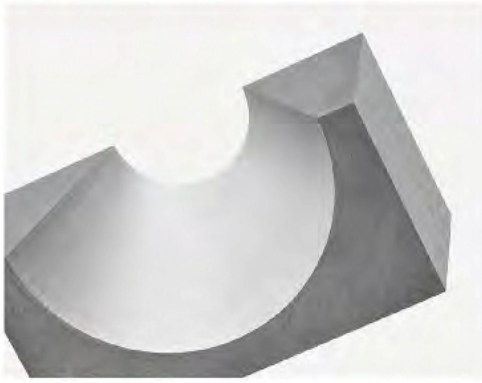

高公差配件 High Tolerance fitting

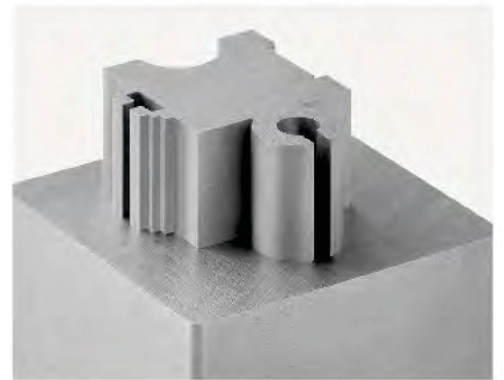
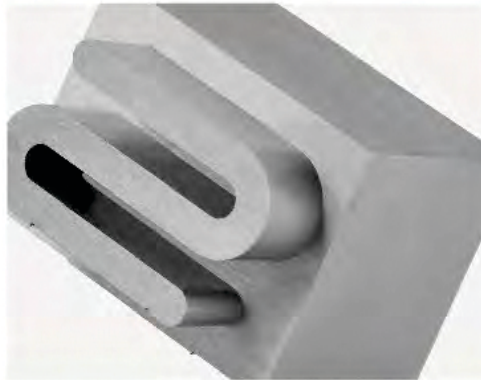
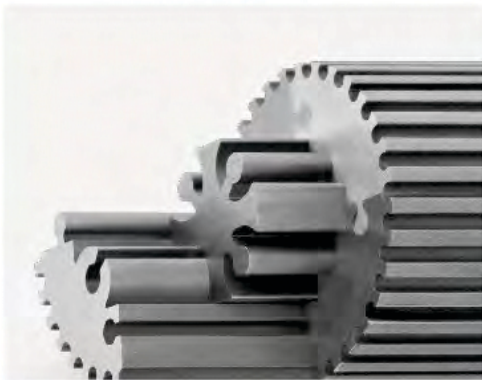

超细线 Ultra Thin Wire

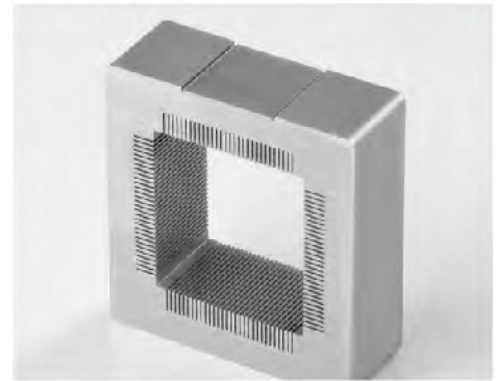
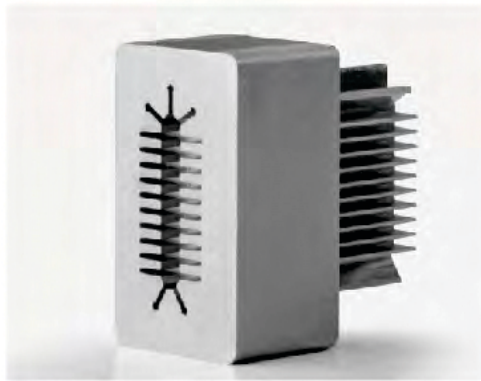

特殊材质 Special Material

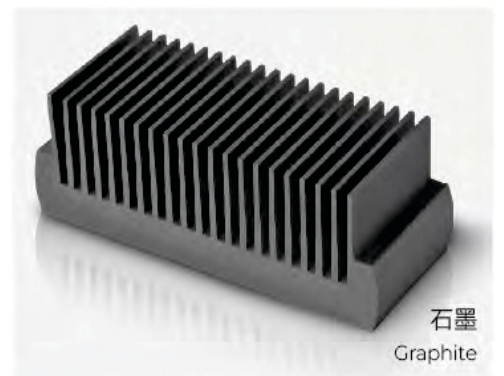
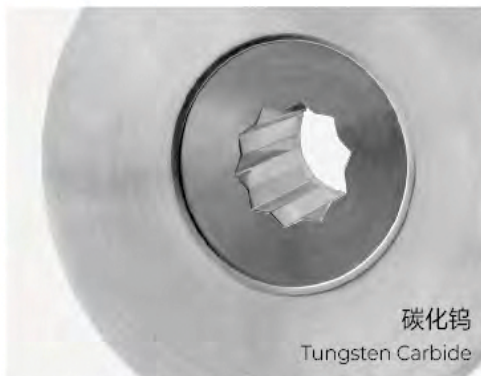
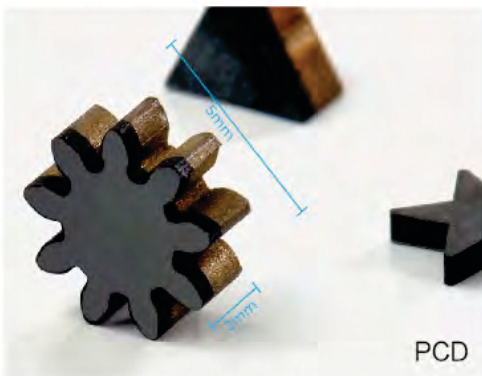

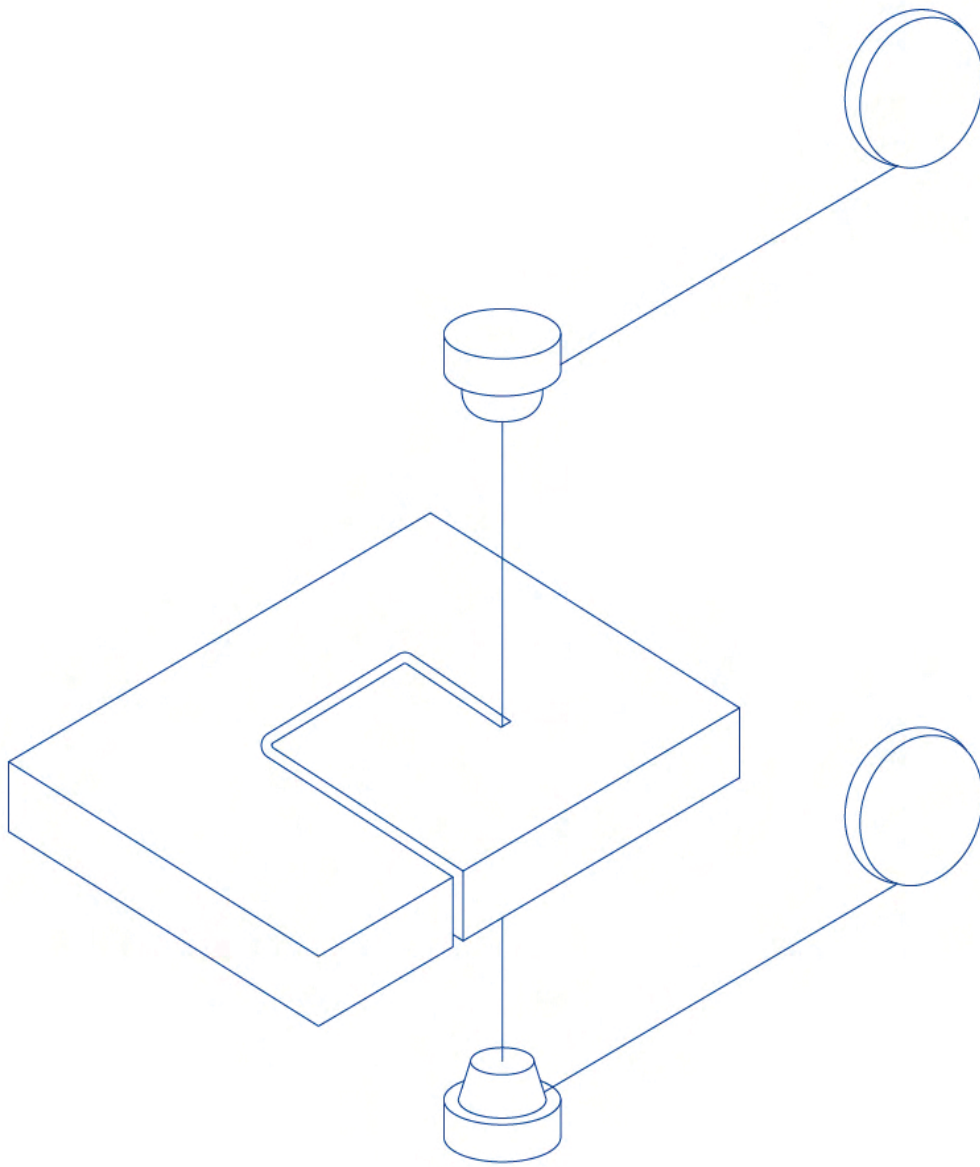

## **ECLAT EDM SOLUTIONS**

**Authorised Dealers in : CNC Wirecut EDM Machines Sales, Spares & Services**

**We also undertake EDM Wirecut jobworks**

**Plot No.47, Ravi Raja Building, TIE Balanagar, Hyderabad - 500037**

**GSTIN : 36AAGFE9512M1Z3**

**Email : eclatedm2018@gmail.com**

**Cell : 9948346176**

**8639199048**